



# **Sika FFI**

## **Solutions for Sealing and Bonding in Facades, Fenestration and Insulating Glass**



**Innovation & Consistency** | since 1910





**Protection against heat, cold, wind, rain, humidity, noise**

**Safety for burglary resistance, fire protection, bomb blast resistance**

**Aesthetics by design freedom, choice of materials, non-staining**

**Profitability because of durability of materials, energy saving, low maintenance cost**

## **Introduction – Facade and Windows**

The building envelope design is a central part of the building's planning process. The facade not only provides the first visual impression of the building but also impacts the climate control of the building and thus the way we feel in the building.

Therefore the design requirements of the facade are manifold and have become increasingly demanding. The standards for energy saving and gain have become more stringent and will strongly influence future developments. The challenge is to develop sustainable systems and components which meet the requirements of modern design and ensure safe and economical facade and window construction.

Sika continues to develop new products and systems for sealing and bonding facades and windows to meet the demands of systems for the latest technology know-how. Sika aims to develop its sealing and bonding technologies to meet the specific market requirements in close cooperation with leading architects/specifiers and curtain wall and window fabricators.



# Sika® Solutions for Sealing and Bonding in Facades

## Curtain Wall Facade

- Ⓐ Structural glazing, insulating glass, weathersealing
- Ⓑ Natural stone facade
- Ⓒ Panel reinforcing, panel lamination
- Ⓓ Glass wall grouting, glass-to-glass applications

## Ventilated Facade

- Ⓔ Panel bonding, water/vapour proofing, chemical anchoring
- Ⓕ Window bonding, general bonding, water/vapour proofing

For descriptions of details please see pages 6 – 8.





### **Curtain Wall Facade**

A curtain wall facade is a lightweight multifunctional building envelope made of glass (single- or multi-pane units), metal, stone or composite panels. These panels are fixed to a metal subframe, either with pressure plates (capped systems) or bonded with silicone adhesive sealants (structural glazing). This system is mechanically fixed to the main building structure. Curtain wall facades are the state-of-the-art technology for high-rise buildings.



### **Ventilated Facade**

Ventilated facades consist of a wall construction, mainly concrete or steel, with an external (or internal) insulating layer and decorative envelope. The air gap between the insulating and decorative surfaces is used for the ventilation of the facade.

The decorative panels can be made of a variety of material such as metal, composite materials, ceramics, timber etc. and offer the architect significant freedom of design.

# Curtain Wall Facades

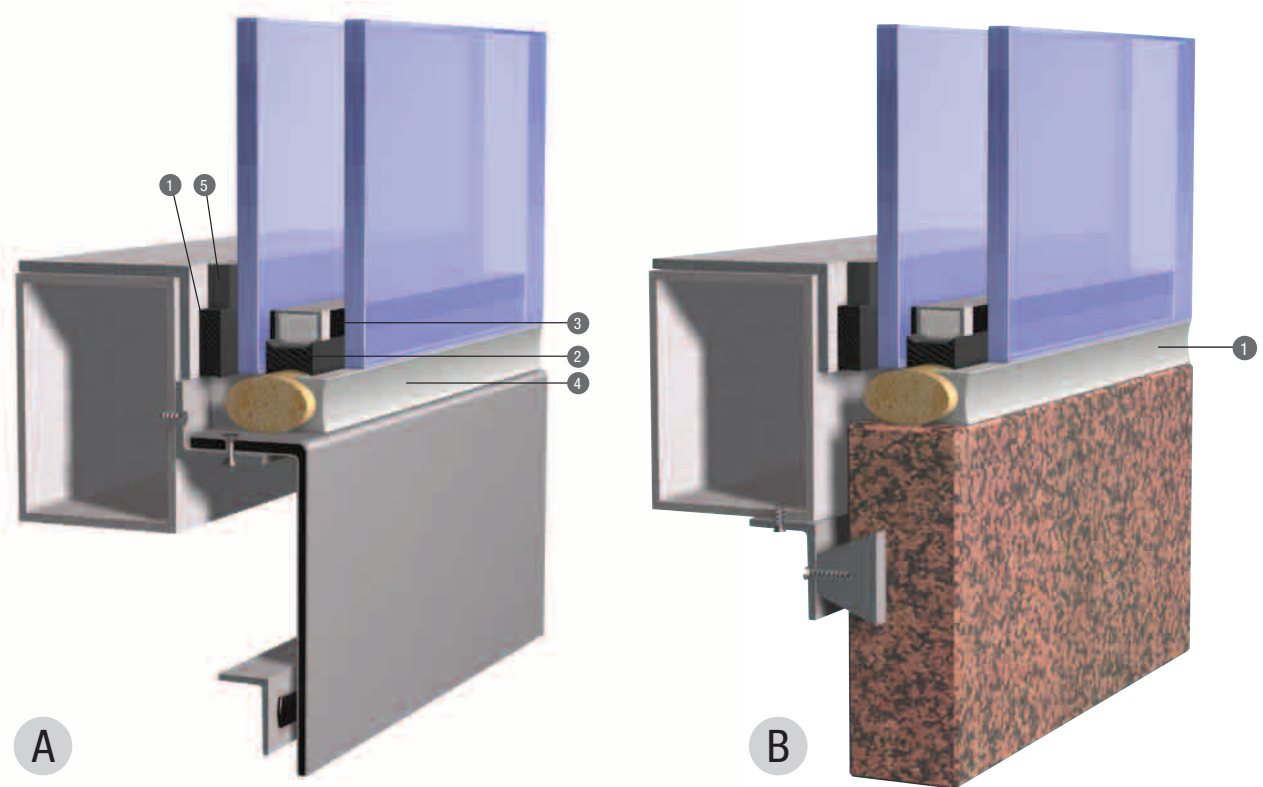

## Structural Glazing

Sika's structural glazing adhesive sealants Sikasil® SG-18, SG-20, SG-500 and SG-500 CN have shown their excellent UV resistance and weather-ability in major projects around the globe. The high-modulus SG adhesive Sikasil SG-550 allows minimised joint bites.

- ① **Sikasil® SG-500, Sikasil® SG-500 CN, Sikasil® SG-550**
- ① **Sikasil® SG-18, Sikasil® SG-20**

## Insulating Glass

Sika offers a complete product range for IG edge sealing. Argon-filled IG units with the UV resistant silicone edge seal Sikasil® IG-25 HM Plus are suitable for structurally glazed facades. For air-filled IG units Sikasil® IG-25 is also applicable. SikaGlaze® IG-50 is mainly used in IG units for structurally bonded windows.

- ② **Sikasil® IG-25**
- ② **Sikasil® IG-25 HM Plus**
- ② **SikaGlaze® IG-50 PU Secondary Seal**
- ③ **SikaGlaze® IG-5 PIB Primary Seal**

## Weathersealing

Structural glazing systems can have many sealants and adhesives which come into contact with each other and with many other materials. They require high-quality products which are compatible with all substrates and ancillary products. Therefore Sika not only supplies the sealants and adhesives but also glazing tapes.

- ④ **Sikasil® WS-605 S**
- ④ **Sikasil® WS-305 CN**
- ⑤ **Sika® Spacer Tape HD**

## Non-staining Weathersealing

Natural stones such as granite, marble, sandstone etc. are naturally occurring and vary in properties, which make them very sensitive construction materials. The use of the non-staining silicone sealant Sikasil® WS-355 for weathersealing of natural stone facades is a must. The compatibility of the sealant with the stone should be tested in one of Sika's Facade Competence Centres before use. Sikasil® WS-680 SC is suitable for sealing self-cleaning glass.

- ① **Sikasil® WS-355**
- ① **Sikasil® WS-680 SC**

## Fire-resistant Facades

Sika's fire-resistant weathersealant Sikasil® FS-665 for curtain wall facades has been tested to BS476, part 20 with 4 hours fire resistance. The self-levelling version Sikasil® FS-665 SL has been optimized for floor joint applications. Sikacryl® FS-265 completes the product range for interior application.

- Sikasil® FS-665**
- Sikasil® FS-665 SL**
- Sikacryl® FS-265**





C

### Panel Reinforcing

Big panels become fashionable in facades. In order to save weight, the panels get thinner and thinner. To stabilize against fluttering, the panels are stiffened with a metal or plastic profile bonded to the back side.

- ① **SikaFast® Acrylic Adhesives**
- ① **SikaPower® Epoxy Hybrid Adhesives**
- ① **Sikasil® SG Silicone Adhesives**
- ① **SikaBond® PU Adhesives**

### Panel Lamination

Sika supplies adhesives for the production of sandwich panels combining many kinds of materials for thermal insulation in the spandrel sections.

- ② **SikaForce® PU Systems**

### Did you know?

**Sikasil® SG-550** ( $\sigma_{dyn} = 0.20 \text{ N/mm}^2$ ) and **Sikasil® IG-25 HM Plus** ( $\sigma_{dyn} = 0.19 \text{ N/mm}^2$ ) achieve the highest ETA approved design stresses in tension in the market. This allows minimised joint sizes.

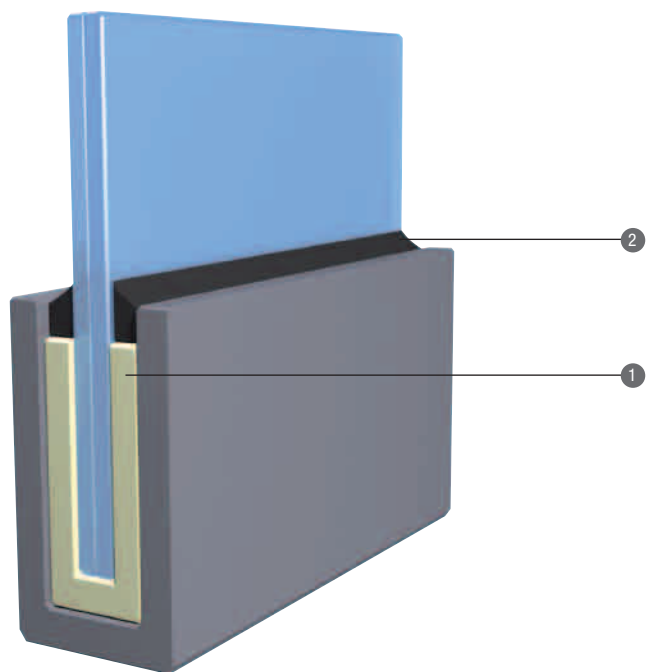

D

### Glass Wall Grouting

In total vision glazing (TVG, fin glazing) and glass balustrades the glass panes should be fixed to the floor (low punctual stress transfer to the glass). With Sika® Icosit® and SikaGlaze® GG the bottom glass edge is embedded in the floor, and thus results in uniform stress distribution. The PU embedding is protected against weathering by Sikasil® WS silicone sealants.

- ① **Sika® Icosit® KC PU Systems**
- ① **SikaGlaze® GG PU Systems**
- ② **Sikasil® WS-605 S**

### Glass-to-Glass Constructions

Sika offers various silicone sealants for glass-to-glass applications: Sikasil®GS-621 for sealing of monolithic glass and Sikasil® WS-305 CN and Sikasil® WS-605 S for sealing of laminated glass. High-modulus Sikasil® SG-18, SG-20 are used for high-strength glass-to-glass bonding.

- Sikasil® WS-605 S**
- Sikasil® WS-305 CN**
- Sikasil® GS-621**
- Sikasil® SG-18**
- Sikasil® SG-20**

# Ventilated Facades

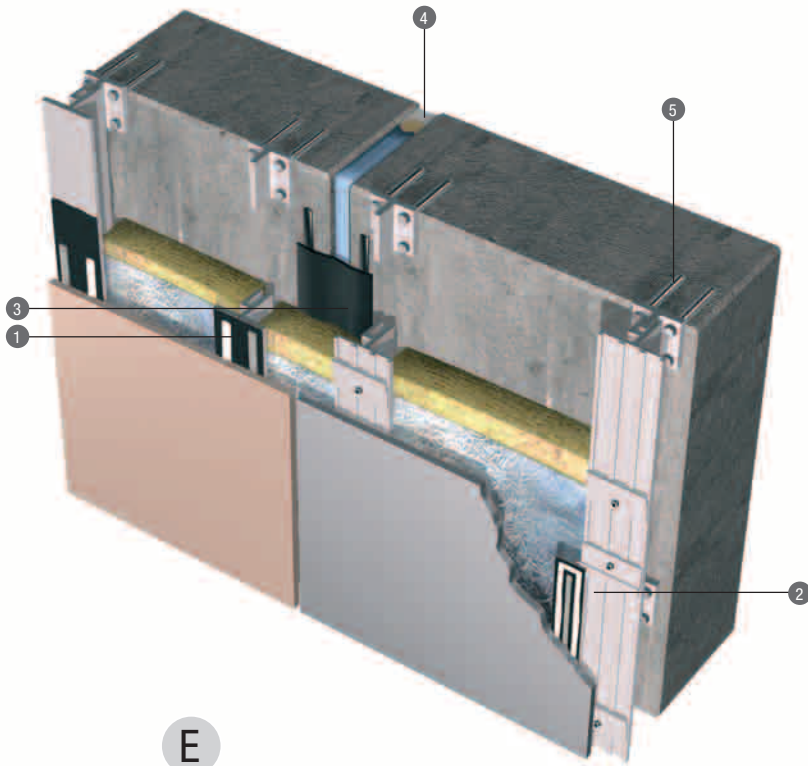

E

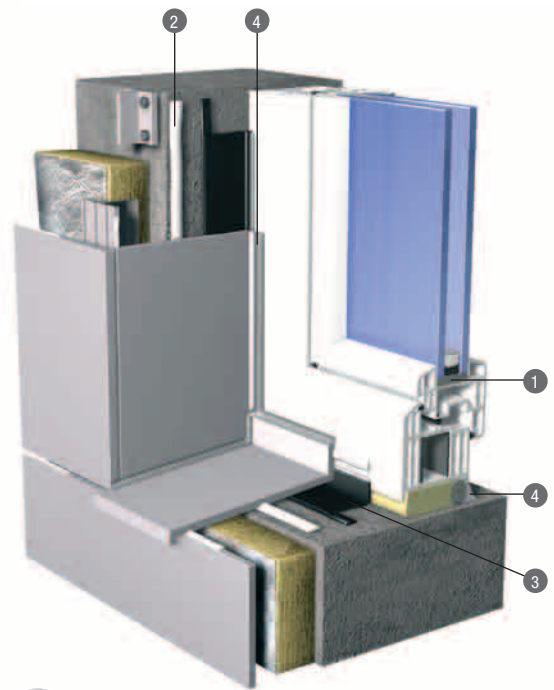

F

## Panel Bonding

The SikaTack®-Panel System consists of an adhesive and a prefiring tape and can be used in two different ways.

1. On-site bonding (left): An aluminium profile (substructure) is anchored to the concrete wall. The panel is glued to the profile. A double-sided adhesive tape holds the panel during the full vulcanization of the glue.

2. Factory prefabrication (right): An aluminium profile is glued to the panel back side in the factory. The fixing rail is anchored to the wall and is brought into line. The fasteners are adjusted to hold the panel at the fixing profile on the back.

Both technologies provide a great design freedom.

- ① **SikaTack®-Panel System** (on-site bonding)
- ② **SikaTack®-Panel System** (factory prefabrication)
- ⑤ **Sika AnchorFix®**

## Structural Window Bonding

Window bonding is an innovative technology where the glass is directly bonded to the sash. The glass stiffens the sash and allows weight reduction of sash material and minimizing the sash width. All loads are uniformly transferred to the sash by replacing the setting blocks by an adhesive applied on all four sides. This minimizes the risk of glass breakage.

- ① **Sikasil® WT Silicone Adhesives**
- ① **Sikaflex® PU Systems**
- ① **SikaFast® Acrylic Adhesives**

## General Bonding

Sika has developed a wide product range for many bonding applications.

- ② **SikaBond® PU and PU-Hybrid Systems**

## Water/Vapour Proofing (In details E and F)

Depending on the climatic conditions both wet sealants (Sikaflex® PU or Sikasil® silicone) or SikaMembran® Systems can be used for movement/connection joints and perimeter sealing around the window frames. SikaMembran® Systems are high-quality systems with optimized water/vapour diffusion resistance levels.

- ③ **SikaMembran® Systems**
- ④ **Sikaflex® Sealants**
- ④ **Sikasil® WS-605 S**



# Sika® Solutions at a Glance



## Bonding Technologies

### Structural Glazing and Insulating Glass Edge Sealing

Sikasil® SG and Sikasil® IG: high-modulus silicone technology for glass bonding and IG edge sealing.

### Panel Bonding

SikaTack®-Panel System: the high-strength PU technology for facade panel bonding.

### Panel Lamination

SikaForce®: PU adhesives for production of sandwich panels.

### Panel Reinforcement (Panel Strengthening)

SikaBond®, SikaFast®, SikaPower®, Sikasil® SG: various products for different bonding technologies for an efficient reinforcement of facade panels and claddings.

### Fenestration: Window Bonding

SikaFast®, Sikaflex®, Sikasil® WT: various products for structural strengthening of window sashes by direct bonding of IG units to the sash made of any kind of material.

## Sealing Technologies

### Joint Sealing

Sikasil® WS: the specialized low-modulus silicones for glass, metals, natural stones and plastics.

Sikaflex®: the high-end PU and PU-hybrid sealants for movement and connection joints preferably on porous substrates.

### Joint Membranes

SikaMembran® Systems: the flexible high-quality membranes for joint sealing in line with the highest requirements of construction physics.

## Anchoring Technologies

Sika® AnchorFix®: the high-strength and fast-curing solution for chemical anchoring.

## Grouting Technologies

Sika® Icosit® and SikaForce®: high-strength, self-levelling PU systems for embedding glass panes of glass walls and balustrades.

Sikasil® IG

Sikasil® SG

Sikasil® WS

Sikasil® GS

Sikasil® FS

Sikasil® WT

Sikaflex®

SikaMembran® Systems

SikaTack®-Panel System

SikaForce®

SikaBond®

SikaFast®

Sika® AnchorFix®

Sika® Icosit®

Sikacryl®

SikaGlaze®

Exhibition Centre, Milan.

The individual pavilions of the Exhibition Centre Nuovo Polo di Fiera Milano are linked by a glass roof of 1300 m by 30 m. The design of the curved free-formed glass roof by Massimiliano Fuksas absorbs the nearby Alps. The mix of glass and aluminium panels (4300 m<sup>2</sup>) has been sealed with Sikasil®WS weathersealants on a length of 80 km.



# Sika's Facade and Fenestration Competence

## Technical Service: FFI Competence Centres

At our FFI Competence Centres we develop new products and processing technologies, test sealing and bonding methods.

The specialists at our FFI Competence Centres provide individualized project service and support for projects on all continents – from planning through to execution:

- Technical support with design and dimensioning details
- Comprehensive adhesion and compatibility tests with original materials
- Support with performing external tests
- Activ consulting with the selection of application technology
- System and equipment engineering
- Applicator training and practical assistance at the FFI Competence Centres and on site
- Warranty procedures

## Our Performance – Your Benefits

Sika places great importance on interdisciplinary cooperation with its partners in the glass, window and curtain wall industry, especially in the development of new products for sealing and bonding technologies. Thus Sika offers complete ready-to-install solutions for integrated facade and window systems.

## A Quick Glance at our Global Experience

- 1 **Riverbank House,**  
London, GB: SG, WS, MB, GG
- 2 **Cloud Nine Plaza,**  
Shanghai, CN: SG, WS
- 3 **Drugstore Publicis, Paris, FR:** SG
- 4 **ADIA, Abu Dhabi, AE:** MB
- 5 **Telefonica HQ, Madrid, ES:** IG
- 6 **Water Cube, Beijing, CN:** WS
- 7 **Lifelong Learning Centre,**  
Barking, UK: TP
- 8 **Bank Negara,**  
Kuala Lumpur, MY: SG, WS

- SG Structural glazing  
Sikasil® SG-500, SG-500 CN
- IG Insulating glass edge sealing  
Sikasil® IG-25 HM Plus, SikaGlaze® IG-5 PIB
- WS Weather sealing  
Sikasil® WS-605 S, WS-305 CN, WS-355
- MB Water- / vapour-proofing  
SikaMembran® System
- GG Glass wall embedding  
SikaGlaze® GG-735, Sika® Icosit® KC340/7
- TP Elastic panel bonding  
SikaTack-Panel® System





## Each Facade is Different – Sika has the Right Solutions

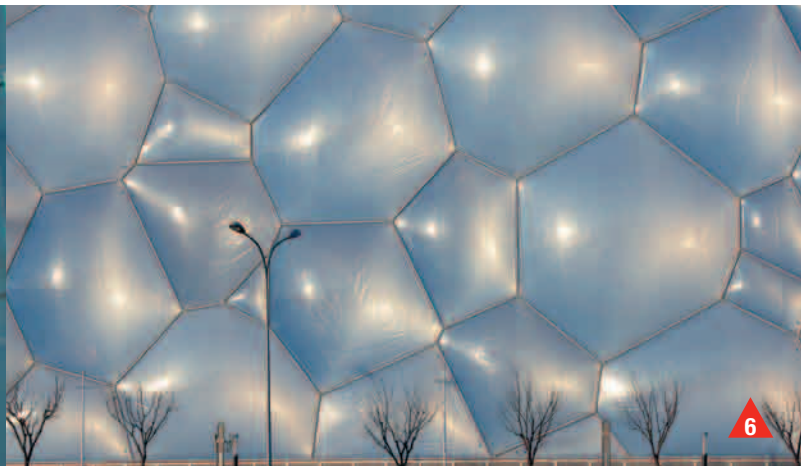

# Sika Worldwide



Sika is a globally active company supplying the specialty chemicals markets. It is a leader in processing materials used in sealing, bonding, damping, reinforcing and protecting load-bearing structures in construction (buildings and infrastructure construction) and in industry (vehicle, building component and equipment production).

Sika's product lines feature high-quality concrete admixtures, specialty mortars, sealants and adhesives, damping and reinforcing materials, structural strengthening systems, industrial flooring and membranes. Subsidiaries in more than 74 countries worldwide and approximately 13,500 employees link customers directly to Sika.

## Technical Service

Sika Services AG  
Facade Competence Centre  
Tüffenwies 16  
CH-8048 Zürich  
Phone +41 58 436 5287  
Fax +41 58 436 5407  
ch-fcc@ch.sika.com

## Customer Service

Sika Engineering Silicones Srl.  
Via L. Einaudi, 6  
I-20068 Peschiera Borromeo (MI)  
Phone +39 02 516591 205  
Fax +39 02 516591 298  
it-ses-admin@it.sika.com



Our most current General Sales Conditions shall apply. Please consult the most current local Product Data Sheet prior to any use.

[www.sika.com/ses](http://www.sika.com/ses)



**Innovation & Consistency** | since 1910