

Industry



Sandwich Panels

Building for the Future



Delivering Your Solution

The market is seeing increasing demands for energy efficient buildings, temperature controlled environments and fire performance products that are aesthetically pleasing and cost effective. As a result, designers and producers must continually find improved solutions which have enhanced performance and at the same time are increasingly efficient to produce.

Sika can supply you with high quality solutions for a wide range of applications in building components production. Bonding, sealing and laminating operations can be carried out using Sika products through the various stages of your production.

Our experts are available worldwide to evaluate your production bonding process and help you achieve the most efficient and cost effective solution.

SikaForce[®] polyurethane adhesives for sandwich panel bonding and structural assembly

SikaMelt[®] reactive polyurethane hot melt adhesives for fast process sandwich panel bonding, lamination and rapid assembly

SikaTherm[®] and **SikaSense**[®] water and solvent based adhesives for a range of laminating applications

Sikaflex[®] and **Sikasil**[®] polyurethane and silicone elastic adhesives for sealing and bonding

SikaFast[®] reactive acrylic adhesives for rapid assembly uses

- 1 Insulated Building Panels
- 2 Decorative Building Panels
- 3 Door Panels
- 4 Roof Panels
- 5 Structural Assembly
- 6 Panel Sealing

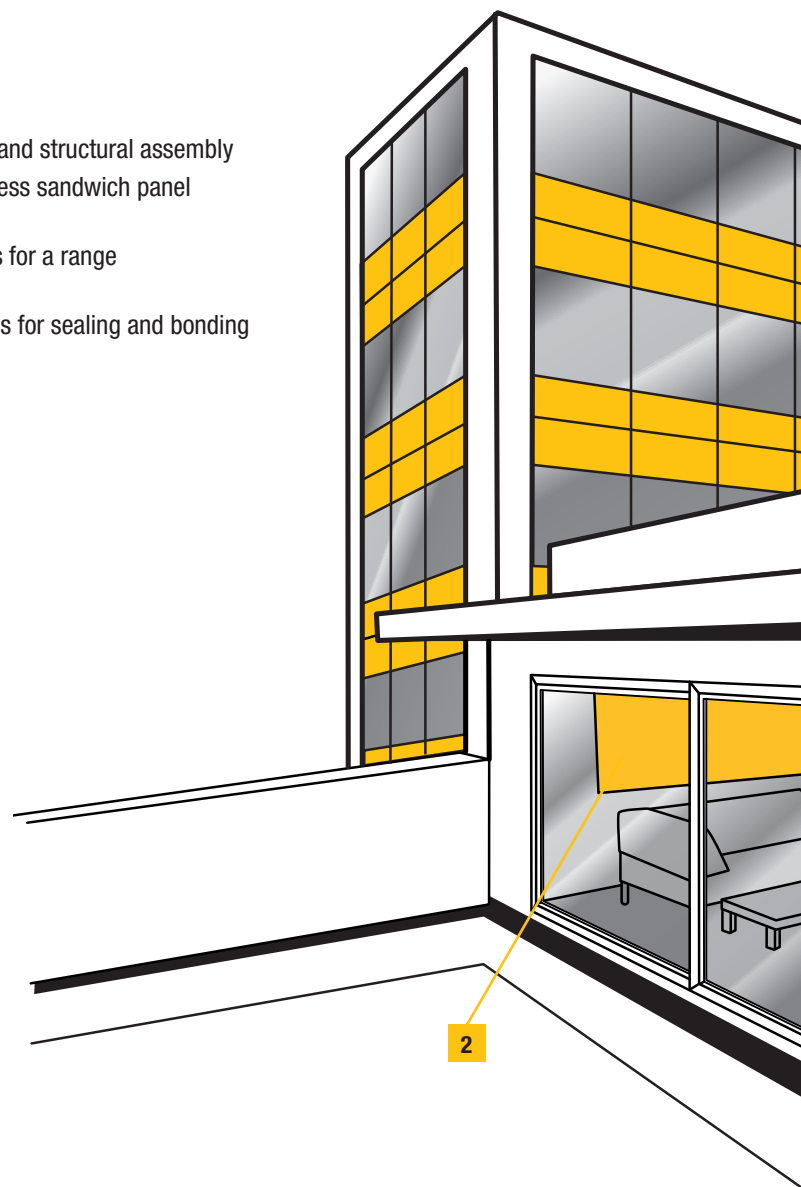

Content

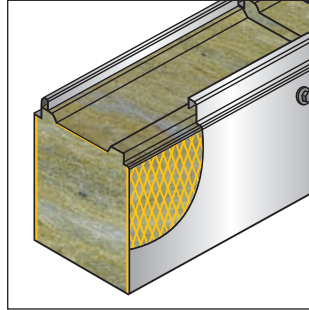

Insulated Building Panels_page 4

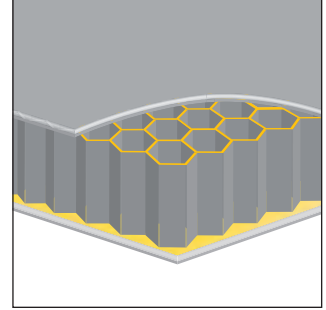

Decorative Building Panels_page 5

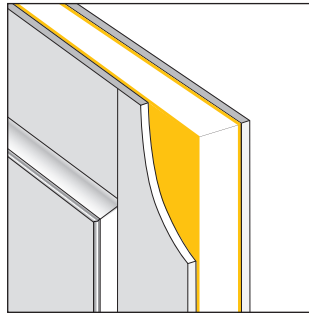

Door Panels_page 6



Creating Profit_page 7

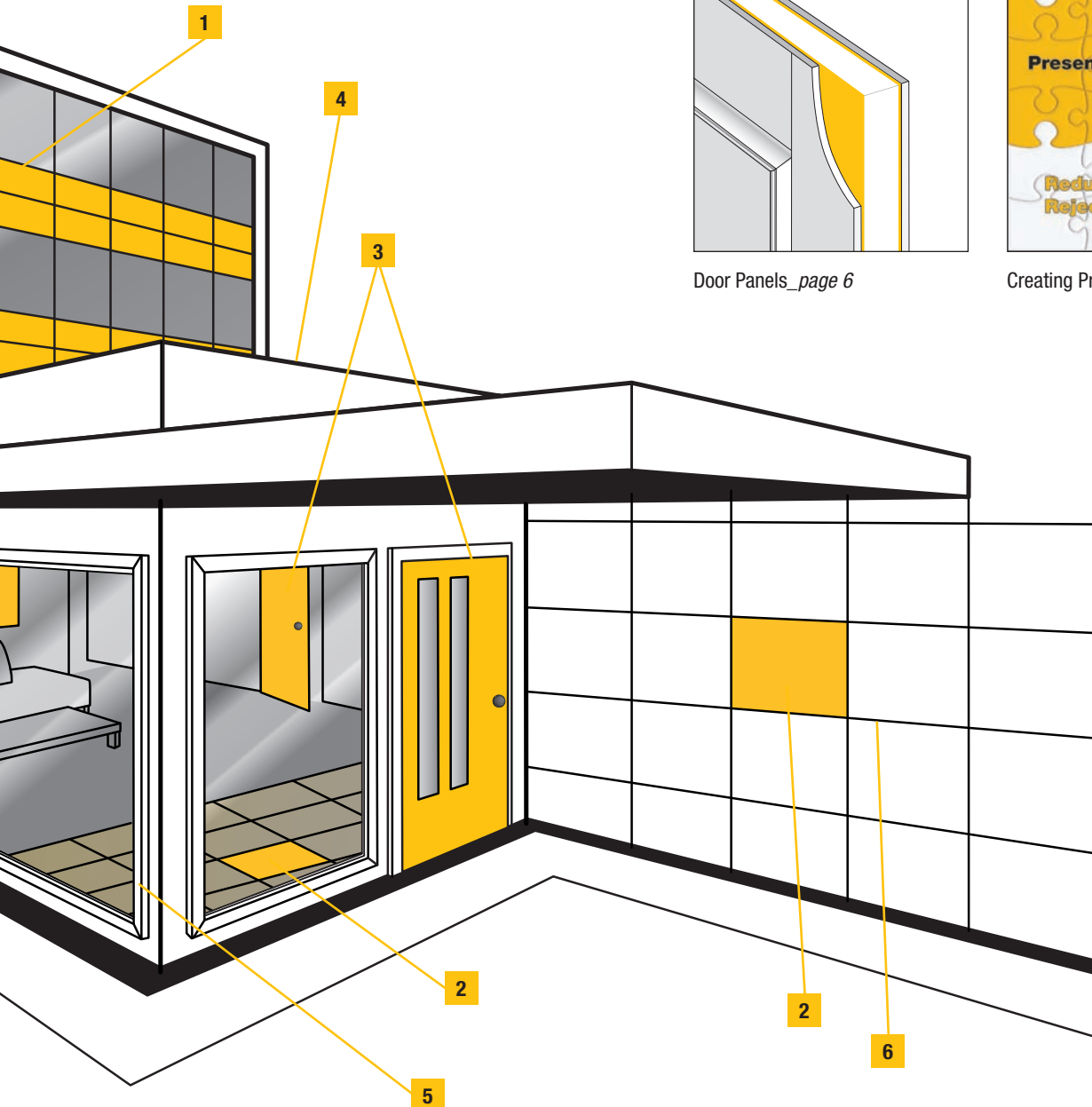

Insulated Building Panels

Why bond Insulated Building Panels?

- Proven technology, with high productivity and low unit cost
- A wide range of core and facing materials can be used allowing greater design freedom within buildings
- Enables the use of mineral fibre cores that give the lowest achievable heat and smoke release
- Open and cure time of the adhesive can be adapted to suit different production line conditions



Product Benefits

- Fast curing systems give high production output
- Optimised coat weight solutions give high strength with a low cost per unit
- Long open time reduces panel scrap due to line stops
- Can be applied by either bead, spray or roller coater

Best Recommended Sika Products

SikaForce®-7110

General purpose family of one component moisture curing polyurethane adhesives having a range of cure speeds

SikaForce®-7740

Two component polyurethane adhesive used for continuous production. Meets the new Euroclass A2, S1, d0 flammability requirements

SikaForce®-7742 and SikaForce®-7202 catalyst

Three component polyurethane adhesive used for continuous production. Meets the new Euroclass A2, S1, d0 flammability requirements

SikaForce®-7010

Curing agent used for both two and three component systems

SikaMelt®-9674 FR

Polyurethane reactive hot melt, flame retarded to give improved fire resistance

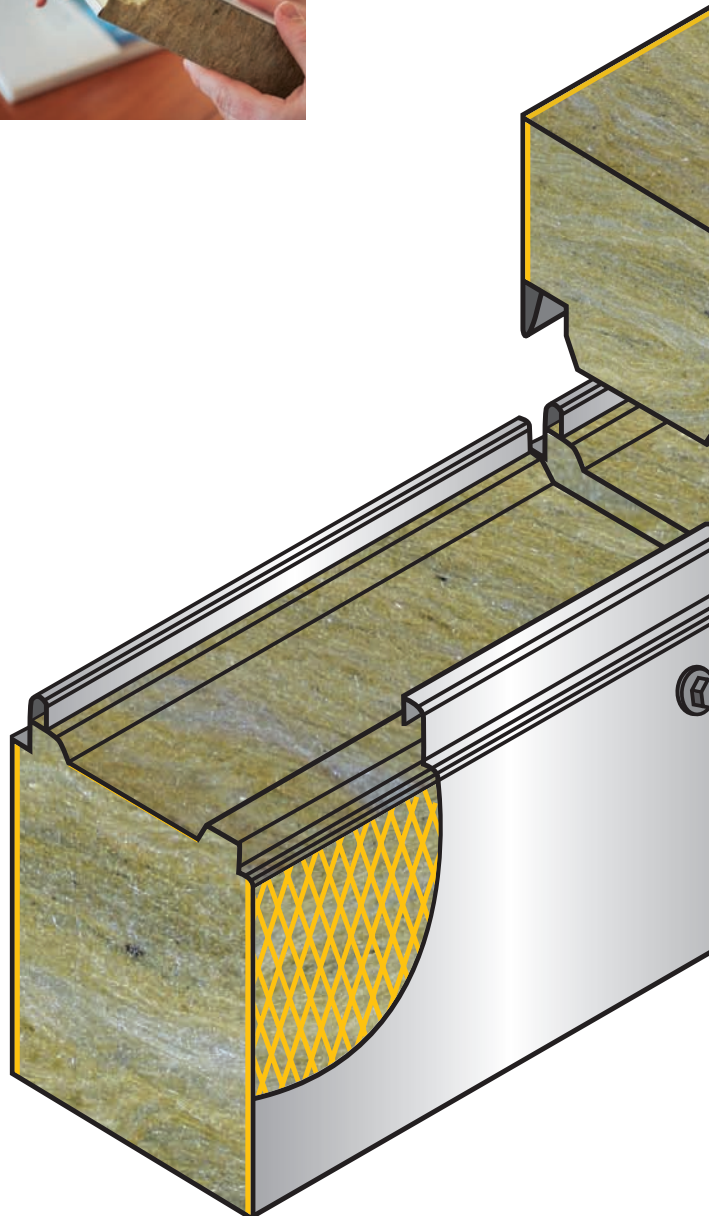

Decorative Building Panels

Why bond Decorative Panels?

- Ideal method for panel assembly
- A wide range of facing materials and cores can be used, allowing greater aesthetic and performance design freedom
- Minimises the effect of galvanic corrosion between dissimilar materials
- Enables the use of foils to change surface appearance

Product Benefits

- Able to bond a wide range of substrates
- High strength solutions for aluminium honeycomb bonding
- Flexible processing - can be applied by either bead, spray or roller coater
- Rapid curing systems with short cycle times

Best Recommended Sika Products

SikaForce® -7110

General purpose family of one component moisture curing polyurethane adhesives having a range of cure speeds

SikaForce® -7710

General purpose family of two component polyurethane adhesives having a range of cure speeds

SikaMelt® -9283

General purpose pressure sensitive hot melt with excellent adhesion and temperature resistance

SikaMelt® -9676 OT

Polyurethane reactive hot melt with long open time and high green strength

SikaMelt® -9675 IS

Polyurethane reactive hot melt with high initial strength for general purpose applications

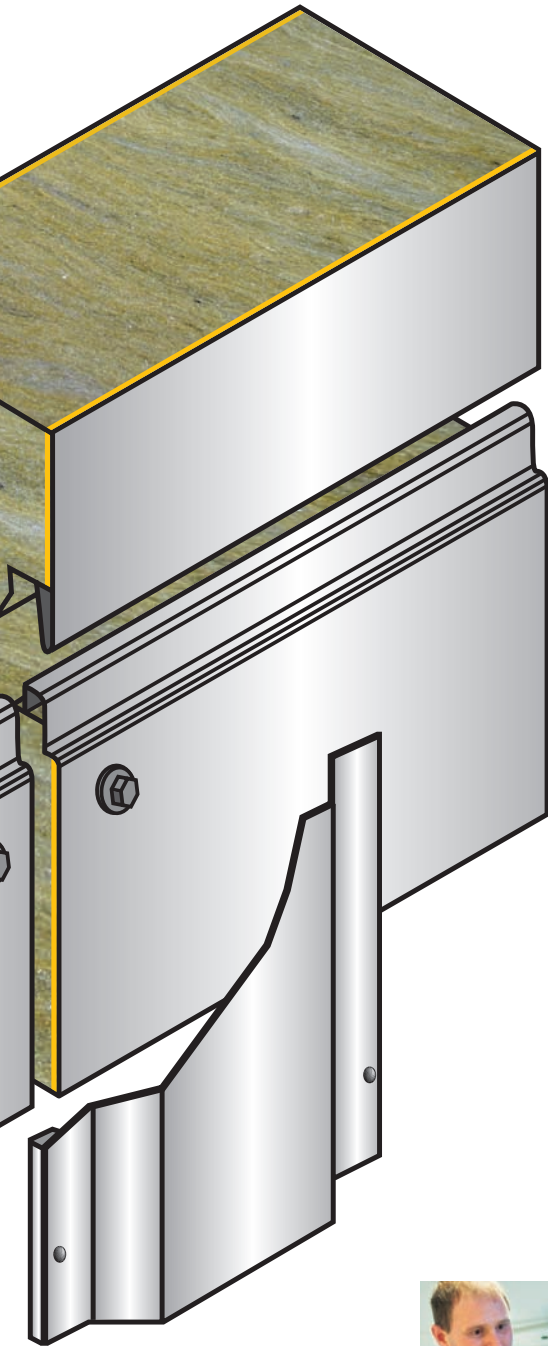

Door Panels

Why bond Door Panels?

- Enables the use of insulating cores to give improved thermal efficiency and reduced heat loss
- A wide range of facing materials, including metals and vacuum formed plastics, can be used allowing greater design freedom
- Performance properties of composite doors can be engineered to suit the specific end use requirements compared to solid doors

Product Benefits

- Bonding directly to a range of substrates, often without the need for surface pre-treatment
- Improved performance and lower cost compared to solid doors
- Flexible processing - can be applied by either bead, spray or roller coater
- High initial handling strength systems for short processing times

Best Recommended Sika Products

SikaForce® -7120

One component moisture curing polyurethane adhesive specifically designed for bonding plastic facing materials

SikaForce® -7710

General purpose family of two component polyurethane adhesives having a range of cure speeds

SikaMelt® -9675 IS

Polyurethane reactive hot melt with high initial strength for general purpose applications

SikaMelt® -9674 LV

Polyurethane reactive hot melt, low viscosity for foil lamination and panel bonding

SikaMelt® -9676

Polyurethane reactive hot melt with high initial strength specifically designed for bonding plastic facing materials

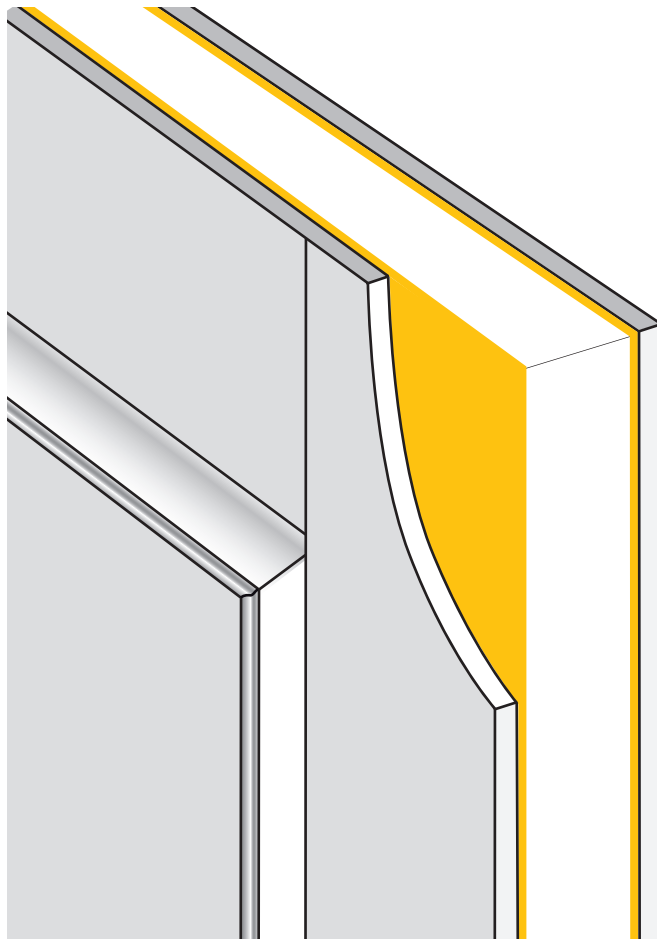

Creating Profit

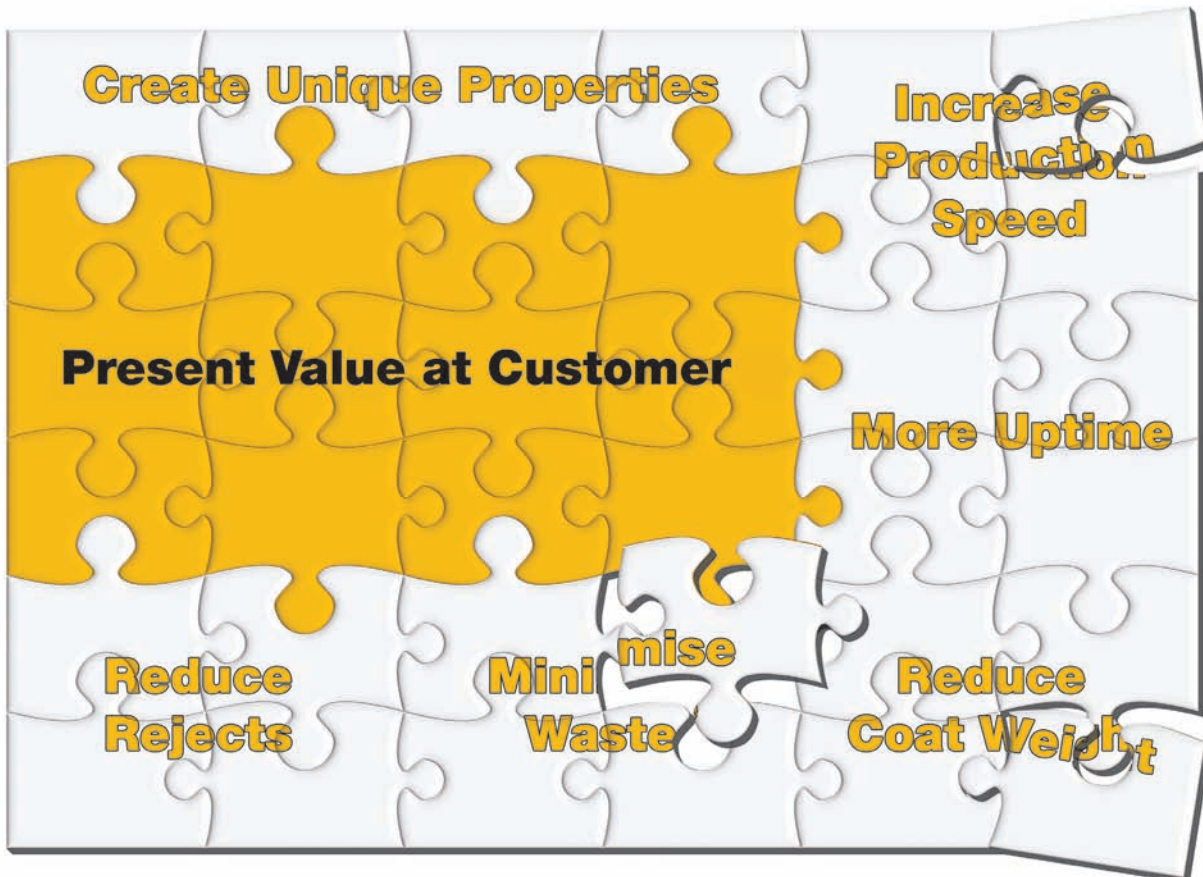

Sika has strived for many years to develop tailored solutions for sandwich panel bonding applications. In our products and services we aim to give you the highest possible bonding efficiency by optimising your production process in key areas that can deliver you increased profitability.



We do this by offering the services of our technical experts who can visit you at your factory and audit your production bonding process.

Together, we can measure the key process parameters and identify potential areas for improvement, such as reducing unit cycle time, increasing production speed, reducing waste and optimising coat weight.

Based on this we can recommend adhesives and production processes to:

-  Reduce your unit cost
-  Increase your productivity
-  Increase your unit profit

To discuss how you can benefit, please contact your local Sika Service and Support Centre.



Sika Worldwide

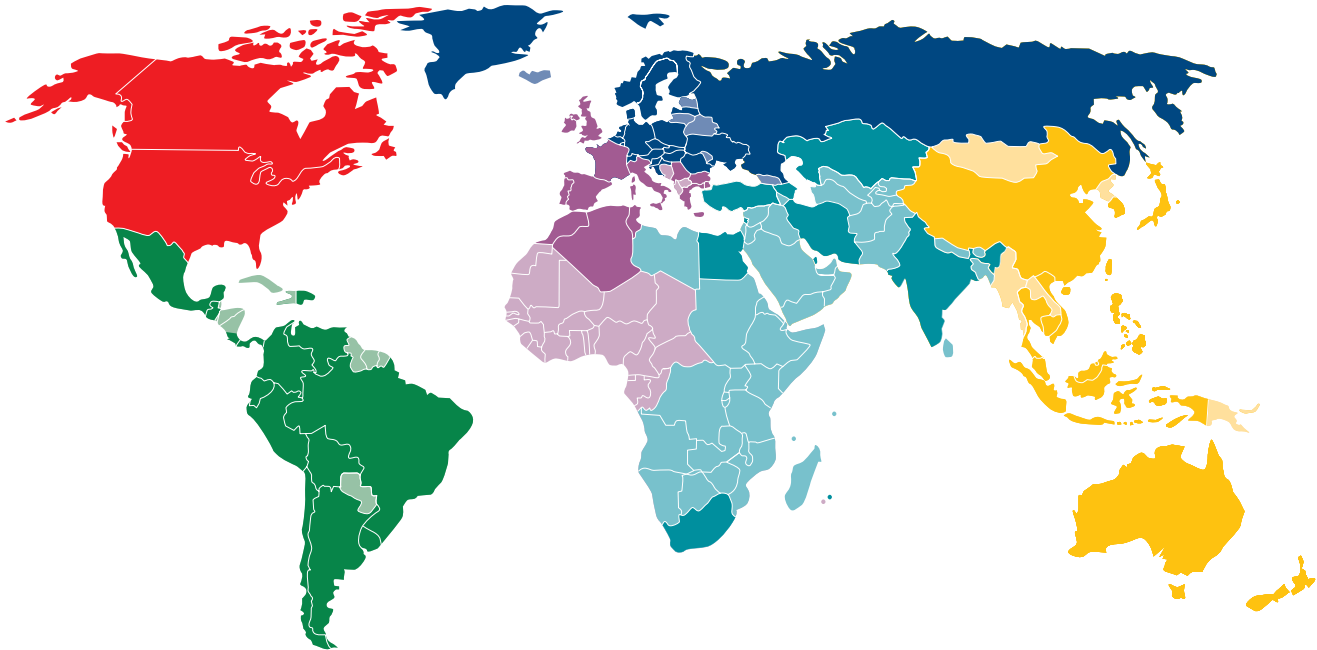

Sika is a globally active company supplying the specialty chemicals markets. It is a leader in processing materials used in sealing, bonding, damping, reinforcing and protecting load-bearing structures in construction (buildings and infrastructure construction) and in industry (vehicle, building component and equipment production).

Sika's product lines feature high-quality concrete admixtures, specialty mortars, sealants and adhesives, damping and reinforcing materials, structural strengthening systems, industrial flooring and membranes. Subsidiaries in more than 70 countries worldwide and approximately 12,000 employees link customers directly to Sika.



Our most current General Sales Conditions shall apply. Please consult the most current local Product Data Sheet prior to any use.

www.sika.com

